

## GL7330 (70/140MHz) IF Link



### Features & Benefits

- 10Km Transmission Distance
- Selectable AGC/MGC
- Front Panel Test Port
- Powerful Monitoring Features
- Compatible with all 1<sup>st</sup> Generation Sat-Light Products

### Product Description

Foxcom's Sat-Light/Gold 70/140MHz IF Link offers a high performance, cost effective alternative to conventional coaxial-cabled systems. Sat-Light/Gold L-Band IFL operates from range of 10 to 200MHz. The Gold Series L-Band link is designed for a wide range of satellite up and downlinking facilities whereby high CNR levels are required. Foxcom's high dynamic range DFB laser delivers exceptional signal quality for the most demanding of applications.

The new Sat-Light Gold series is compatible with first generation Sat-Light 7000 Series platform. The Gold Series support L-Band, 70/140MHz IF, Wide Band (10-2200 MHz), 10MHz Reference, Redundancy, M & C, SNMP, Ethernet, and Serial Data Communication.

The link consists of a high input power optical transmitter, which receives the RF signal from an IF modem, and an optical receiver that connects to the antenna BUC. All satellite modulation schemes are accommodated –digital or analog. Inherently low phase is achieved by direct modulation of the laser diode.

<b>GL7330 RF Optical Link IF [70-140MHz], 4dB Optical Budget</b>				
<b>RF Specifications</b>	<b>Units</b>	<b>Typical</b>	<b>Minimum</b>	<b>Maximum</b>
Frequency Range	MHz	10-200MHz		
Link Gain	dB	Adjustable	-10	+10
Amplitude Response @ Unity Gain 10-200MHz any 36 MHz	dB	±0.4 ±0.3		±0.5
Gain Stability	dB/24hr	±0.25		±0.3
SFDR <sup>1</sup>	dB/Hz <sup>2/3</sup>		100	
CNR [any 36 MHz] <sup>1</sup>	dB	60	57	
Noise Figure (NF) <sup>2</sup>	dB	18		21
Output IP3 (OIP3) <sup>3</sup>	dBm	+20	+15	
Third Order InterModulation [IMD] <sup>4</sup>	dBc	Adjustable	55	40
Group Delay Variation- linear 10-25MHz 25-200MHz	Ns	5 1		
Input Signal Range - Total Power	dBm		-30	0
Output Signal Range - Total Power	dBm		-25	0
Maximum Input without Damage	dBm		+15	
Input/Output Impedance	75 or 50			
TX/RX Input/Output return loss 50 Ohm 75 Ohm	dB	-15 -12		-15 -12
RF Connector Type Input/Output Test Port		F, SMA BNC		
Test Port [front panel sample port]	dB	-20	-22	-18

<b>Optical Specifications</b>		<b>Typical</b>	<b>Minimum</b>	<b>Maximum</b>
Optical Power Output	dBm	3	1	4
Optical Budget / Distance 4 dB optical budget	dB/Km	1310 nm   1550 nm 8  15		
Optical Connector Types		FC/APC		
Optical Wavelength	nm	1310/1550/CWDM		

Electrical Specification				
Supply Voltage	Vdc	13	12.7	18
Supply Current [TX] <sup>5</sup>	Amp	0.4		
Supply Current (RX)	Amp	0.3		
Physical Specifications				
Operating Temperature Range			-10	+55
Dimensions [D×W×H]				
MTBF	Hours	TX: 309, 481 RX: 359, 057		

1. 0dBm RF input, unity gain, IMD=-40 dBc @ 1 meter Fiber
2. -20dBm RF input, 20dB Gain, IMD=-40 dBc
3. 0dBm RF Output, IMD=-40dBc
4. User adjustable
5. Under 10°C add 120 mA [laser heating]

## Ordering Information

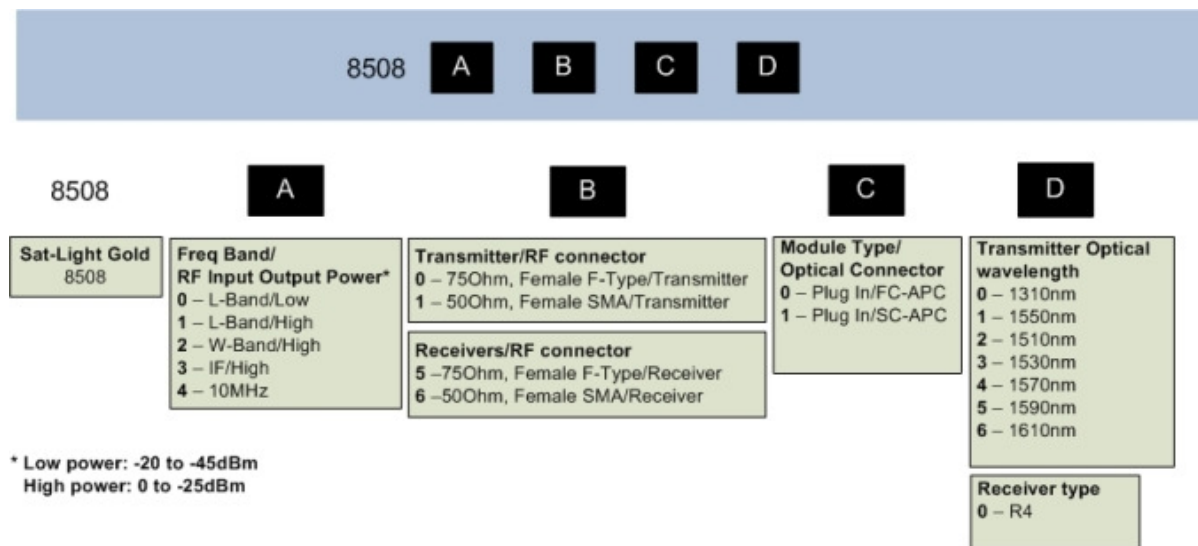

Example: Plug in module, L-band, low RF input, 1310nm laser, F-Type RF connector and FC/APC optical connector

8508 0000